

Moving hospital beds

Safe moving in Hospitals and Aged Care

Moving beds through high traffic departments in hospital corridors, in and out of lifts, increases the risk of a manual handling injury. Simplify the task safely and smartly with a Gzunda Bed Mover.

With the capacity to move up to 600kg, Gzunda Bed Movers enable a single operator to efficiently manoeuvre a fleet of hospital beds in your healthcare facility with minimal effort.

Improving the safety of bed moving within your facility

The Gzunda's easy-to-use controls include a key switch, twist grip throttle, variable speed control, horn and emergency stop button.

All Gzunda Bed Movers come with a standard flex hitch. This hitch provides maximum compatibility with the majority of hospital beds in use today. Using a simple retractable strap and buckle arrangement, the flex hitch enables hospital beds to be quickly and easily attached. We can also easily customise a hitch to suit a variety of hospital bed frames if required.

Bed movers are:

- Easy to use
- Quiet to operate with zero emissions
- Easy to drive with no license required
- Covered by a comprehensive 12 month warranty



CasterDepot

Bed Movers



Gzunda GZS

- 600 kg capacity
- No under-bed clearance required
- Comprehensive 12 month warranty

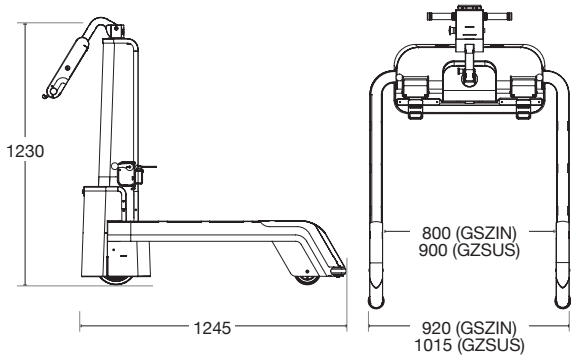

Order Code

Gzunda Bed Mover 600 kg split tyne (International)

GZSIN(NH)*

Gzunda Bed Mover 600 kg split tyne (US)

GZSUS(NH)*



Gzunda GZ10SL

- 500 kg capacity
- Compact and easy to manoeuvre in tight corridors
- Requires 100mm of clearance under the bed (can be modified to 90mm if required)

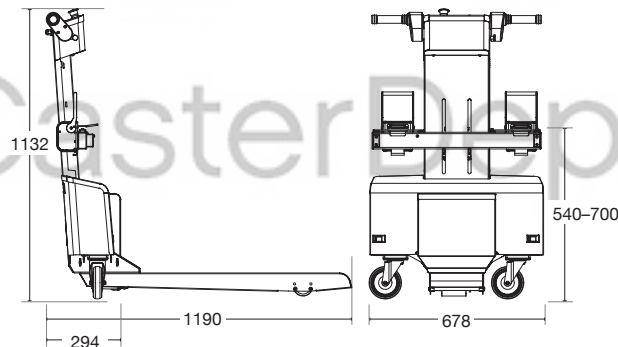

Order Code

Gzunda Bed Mover 500 kg

GZ10SL(NH)*

* NH: Bed Movers are sold without a hitch. Hitches are sold separately to suit the range of bed models in your fleet. See the Electrodrive website for more details.



Gzunda GZS



Gzunda GZ10SL