

# 1 Series

WOOD FURNITURE STEM

Capacity up to **75 lbs each**



### Standard Dimensions

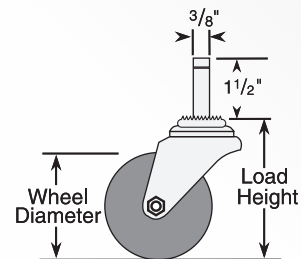

Swivel Cross Section

Fork Leg Spacing 1<sup>5</sup>/<sub>32</sub>"

### Features

- Zinc plated finish is attractive and durable
- Full double ball hardened raceways for better performance and greater durability
- 5/16" shouldered axle with 1/4" nut
- "Colson 45" multi-temp grease lubricates in extreme hot and cold temperatures

### Standard Mounting

- For use on wood furniture that can accept a 3/8" diameter hole approximately 1 5/8" deep
- **Stem Size:** 5/16" diameter x 1 1/2" long
- Standard No. 20 pressed steel adapter (Part #50011) with toothed base is supplied

### Colson 1 Series Casters • Wood Furniture Stem • Capacity to 75 lbs

Wheel Dia.	Tread Width	Capacity Each (Pounds)	Wheel Descriptions	Wheel Bearing	Stem Caster Models	Load Height	Swivel Radius	Weight (Pounds)
1 5/8"	7/8"	60	Perfoma Rubber	Delrin	1.01652.441	2 1/2"	1 3/4"	1/2
		75	Polyolefin	Delrin	1.01652.52	2 1/2"	1 3/4"	1/2
2"	7/8"	75	Perfoma Rubber	Delrin	1.02252.441	2 11/16"	1 15/16"	1/2
			Polyolefin	Delrin	1.02252.52	2 11/16"	1 15/16"	1/2
			Cushion Rubber	Ball	1.02252.45	2 11/16"	1 15/16"	1/2
			Hard Rubber	Ball	1.02252.55	2 11/16"	1 15/16"	1/2
3"	7/8"	75	Perfoma Rubber	Delrin	1.03052.441	3 13/16"	2 9/16"	3/4
			Polyurethane HI-TECH	Delrin	1.03052.91	3 13/16"	2 9/16"	3/4
			Polyolefin	Delrin	1.03052.53	3 13/16"	2 9/16"	3/4

### Caster Brake



**Side Lock**  
(See page 96) Available on all 3" models. Field installable (Specify BRK3).

### Fork Options

**NSF Listed for Food Service Industry**  
All models except thread guards.

**Forks Only**  
To order caster forks only use 1st 6 digits of model numbers (Example: 1.01652).

### Wheel Selection



### Wheel Option

**Thread Guards**  
(See page 108) Available on all 3" models. Brake & NSF options cannot be used with thread guards (Specify TG1 for metal).

# 1 Series

EXPANDING ADAPTER STEM

Capacity up to **145 lbs each**



### Standard Dimensions

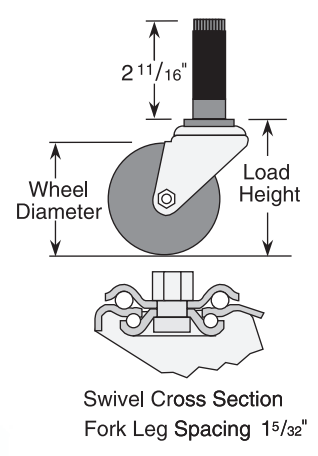

### Features

- Zinc plated finish is attractive and durable
- Full double ball hardened raceways for better performance and greater durability
- 5/16" shouldered axle with 1/4" nut
- "Colson 45" multi-temp grease lubricates in extreme hot and cold temperatures

### Standard Mounting

- Turning of octagon on upper raceway expands rubber adapter inside of round or square tubing for a tight, permanent fit
- To order, select caster model number and specify stem adapter size by code number from mounting options chart at bottom right

## Colson 1 Series Casters • Expanding Adapter Stem • Capacity to 145 lbs each

Wheel Dia.	Tread Width	Capacity Each (Pounds)	Wheel Descriptions	Wheel Bearing	Stem Caster Models*	Load Height	Swivel Radius	Weight (Pounds)
3"	7/8"	100	Polyurethane HI-TECH	Delrin	1.03367.91	3 7/8"	2 13/16"	11/4
		125	Performa Rubber	Delrin	1.03367.441	3 7/8"	2 13/16"	11/4
			Polyolefin	Delrin	1.03367.53	3 7/8"	2 13/16"	11/4
4"	7/8"	125	Polyurethane HI-TECH	Delrin	1.04367.91	4 7/8"	3 7/16"	1 1/2
		135	Performa Rubber	Delrin	1.04367.441	4 7/8"	3 7/16"	1 1/2
			Polyolefin	Delrin	1.04367.53	4 7/8"	3 7/16"	1 1/2
5"	7/8"	140	Polyurethane HI-TECH	Delrin	1.05367.91	5 7/8"	4 1/16"	13/4
			Performa Rubber	Delrin	1.05367.441	5 7/8"	4 1/16"	13/4
			Polyolefin	Delrin	1.05367.53	5 7/8"	4 1/16"	13/4

\*To order you must include mounting code in the Mounting Options chart below (Example: 1.03367.91 MTG40).

Note: Expanding adapter temperature rating is 180°F.

### Caster Brake



**Side Lock (See page 96)**  
Available on all models. Field installable (Specify BRK3).

### Fork Options

**NSF Listed for Food Service Industry**  
All models except thread guards.

**Forks Only**  
To order caster forks only use 1st 6 digits of model numbers (Example: 1.03367).

### Wheel Selection



### Wheel Option

**Thread Guards**  
(See page 108) Available on all 3" models. Brake & NSF options cannot be used with thread guards (Specify TG1 for metal).

### Mounting Options

(See page 107)

Inside Diameter of Tube	Mounting Code Numbers	
	Round Tubing	Square Tubing
3/4" - 13/16"	MTG40	-
7/8" - 15/16"	MTG41	MTG51
1" - 1 1/16"	MTG42	MTG52
1 1/8" - 1 3/16"	MTG43	MTG53
1 1/4" - 1 5/16"	MTG44	MTG54
1 3/8" - 1 7/16"	MTG45	MTG55
1 1/2" - 1 9/16"	MTG46	-
1 5/8" - 1 11/16"	MTG47	-

Stems are 2 1/16" long. Stem size less adapter: 1/2" - 13UNC x 2 1/16"

To order add the mounting code to Stem Caster Models number (Example: 1.03367.91 MTG40).

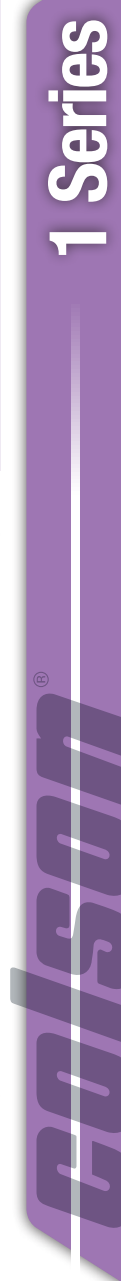

# 1 Series

Capacity up to **75 lbs each**



### Standard Dimensions

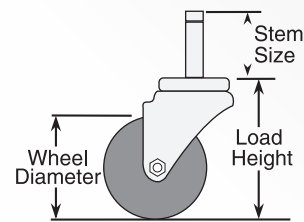

### Features

- Zinc plated finish is attractive and durable
- Full double ball hardened raceways for better performance and greater durability
- 5/16" shouldered axle with 1/4" nut
- "Colson 45" multi-temp grease lubricates in extreme hot and cold temperatures

### Standard Mounting

- Spring grip on top of stem holds caster firmly in place
- **Stem Size:** 7/16" x 1 29/32" long **with** grip ring

### Colson 1 Series Casters • Grip Ring Stem • Capacity to 75 lbs each

Wheel Dia.	Tread Width	Capacity Each (Pounds)	Wheel Descriptions	Wheel Bearing	Stem Caster Models	Load Height	Swivel Radius	Weight (Pounds)
1 5/8"	7/8"	60	Perfoma Rubber	Delrin	1.01651.441	2 1/2"	1 3/4"	1/2
		75	Polyolefin	Delrin	1.01651.52	2 1/2"	1 3/4"	1/2
2"	7/8"	75	Perfoma Rubber	Delrin	1.02251.441	2 11/16"	1 15/16"	1/2
			Polyolefin	Delrin	1.02251.52	2 11/16"	1 15/16"	1/2
			Cushion Rubber	Ball	1.02251.45	2 11/16"	1 15/16"	5/8
			Hard Rubber	Ball	1.02251.55	2 11/16"	1 15/16"	5/8
3"	7/8"	75	Perfoma Rubber	Delrin	1.03051.441	3 13/16"	2 9/16"	3/4
			Polyurethane HI-TECH	Delrin	1.03051.91	3 13/16"	2 9/16"	3/4
			Polyolefin	Delrin	1.03051.53	3 13/16"	2 9/16"	3/4

### Caster Brake



**Side Lock**  
(See page 96) Available on all 3" models. Field installable (Specify **BRK3**).

### Wheel Selection



### Fork Options

**NSF Listed for Food Service Industry**  
All models except thread guards.

#### Forks Only

To order caster forks only use 1st 6 digits of model numbers (Example: 1.01651).

### Wheel Option

#### Thread Guards

(See page 108) Available on all 3" models. Brake & NSF options cannot be used with thread guards (Specify **TG1** for metal).

### Mounting Options

**Standard Mounting (no code necessary):**  
7/16" x 1 29/32" long **with** grip ring.

**MTG1:** 3/8" x 1 9/16" long

**MTG2:** 7/16" x 1 9/16" long

**MTG50:** 7/16" x 1" long

**MTG51:** 7/16" x 1 29/32" long **less** grip ring

**MTG57:** 1/2" x 4 1/2" (ladder caster stem)

To order optional mounting, add mounting code to Stem Caster Models number (Example: 1.01651.441 MTG1).

# 1 Series

Capacity up to **145 lbs each**



## Standard Dimensions

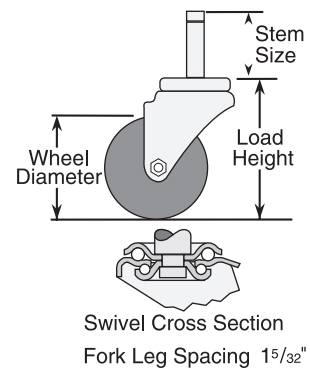

### Features

- Zinc plated finish is attractive and durable
- Full double ball hardened raceways for better performance and greater durability
- 5/16" shouldered axle with 1/4" nut
- "Colson 45" multi-temp grease lubricates in extreme hot and cold temperatures

### Standard Mounting

- Spring grip on top of stem holds caster firmly in place
- **Stem Size:** 7/16" x 1 29/32" long **with** grip ring

## Colson 1 Series Casters • Grip Ring Stem • Capacity to 145 lbs each

Wheel Dia.	Tread Width	Capacity Each (Pounds)	Wheel Descriptions	Wheel Bearing	Stem Caster Models	Load Height	Swivel Radius	Weight (Pounds)
3"	7/8"	100	Polyurethane HI-TECH	Delrin	1.03351.91	33/4"	213/16"	1
		125	Performa Rubber	Delrin	1.03351.441	33/4"	213/16"	11/8
			Polyolefin	Delrin	1.03351.53	33/4"	213/16"	11/8
4"	7/8"	125	Polyurethane HI-TECH	Delrin	1.04351.91	43/4"	37/16"	11/8
		135	Performa Rubber	Delrin	1.04351.441	43/4"	37/16"	13/8
			Polyolefin	Delrin	1.04351.53	43/4"	37/16"	13/8
5"	7/8"	140	Polyurethane HI-TECH	Delrin	1.05351.91	53/4"	41/16"	11/4
		145	Performa Rubber	Delrin	1.05351.441	53/4"	41/16"	15/8
			Polyolefin	Delrin	1.05351.53	53/4"	41/16"	11/8

### Caster Brake



**Side Lock** (See page 96)  
Available on all models. Field installable (Specify **BRK3**).

### Fork Options

**NSF Listed for Food Service Industry**  
All models except thread guards.

#### Forks Only

To order caster forks only use 1st 6 digits of model numbers (Example: 1.03351).

### Wheel Selection

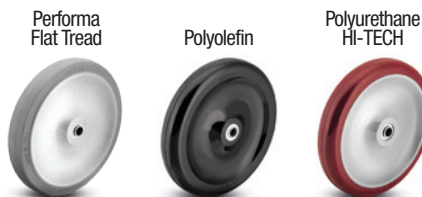

### Wheel Option

**Thread Guards**  
(See page 108) Available on all 3" models. Brake & NSF options cannot be used with thread guards (Specify **TG1** for metal).

### Mounting Options

**Standard Mounting (no code necessary):**  
7/16" x 1 29/32" long **with** grip ring **no** plastic adapter.

**MTG2:** 7/16" x 1 1/2" long

**MTG51:** 7/16" x 1 29/32" long **less** grip ring

To order optional mounting, add mounting code to Stem Caster Model number (Example: 1.03367.91 MTG51).

### Plastic Adapters

Snaps in place to reduce distortion and damage to furniture and equipment tubing.

Plastic adapters are non-conductive. To order, add plastic adapter mounting code from below to Stem Caster Model number (Example: 1.03351.91 MTG53).

**MTG53:** (No. 50810): Fits 7/8" x 18 ga. wall round tubing or any I.D. from 3/4" to 51/64".

**MTG55:** (No. 50865): Fits 1" x 14 ga. wall round tubing or any I.D. from 53/64" to 55/64".

**MTG56:** (No. 50916): Fits 1" x 16 ga. wall round tubing or any I.D. from 57/64" to 29/32".



1 Series

# 1 Series

Capacity up to 75 lbs each



## Standard Dimensions

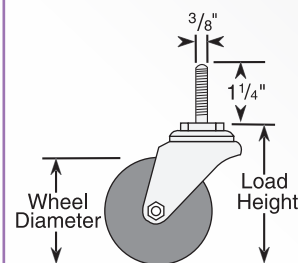

Swivel Cross Section  
Fork Leg Spacing 1<sup>5</sup>/<sub>32</sub>"

## Features

- Zinc plated finish is attractive and durable
- Full double ball hardened raceways for better performance and greater durability
- 5/16" shouldered axle with 1/4" nut
- "Colson 45" multi-temp grease lubricates in extreme hot and cold temperatures

## Standard Mounting

- **Stem Size:** 3/8" diameter - 16UNC x 1 1/4" long threaded 1 1/8"

**IMPORTANT:** If caster stem is to be screwed into customer equipment, the customer must add a washer to the stem that will cover the incomplete threads and support the upper race. The stem shoulder must fit tightly against the customer equipment.

## Colson 1 Series Casters • Threaded Stem • Capacity to 75 lbs each

Wheel Dia.	Tread Width	Capacity Each (Pounds)	Wheel Descriptions	Wheel Bearing	Stem Caster Models	Load Height	Swivel Radius	Weight (Pounds)
1 5/8"	7/8"	60	Perfoma Rubber	Delrin	1.01654.441	2 1/2"	1 3/4"	3/8
		75	Polyolefin	Delrin	1.01654.52	2 1/2"	1 3/4"	3/8
2"	7/8"	75	Perfoma Rubber	Delrin	1.02254.441	2 11/16"	1 15/16"	3/8
			Polyolefin	Delrin	1.02254.52	2 11/16"	1 15/16"	3/8
			Cushion Rubber	Ball	1.02254.45	2 11/16"	1 15/16"	1/2
			Hard Rubber	Ball	1.02254.55	2 11/16"	1 15/16"	1/2
3"	7/8"	75	Perfoma Rubber	Delrin	1.03054.441	3 13/16"	2 9/16"	5/8
			Polyurethane HI-TECH	Delrin	1.03054.91	3 13/16"	2 9/16"	5/8
			Polyolefin	Delrin	1.03054.53	3 13/16"	2 9/16"	5/8

## Caster Brake



**Side Lock**  
(See page 96) Available on all 3" models. Field installable (Specify **BRK3**).

## Wheel Selection



## Fork Options

**NSF Listed for Food Service Industry**  
All models except thread guards.

**Forks Only**  
To order caster forks only use 1st 6 digits of model numbers (Example: 1.01654).

## Wheel Option

**Thread Guards**  
(See page 108) Available on all 3" models. Brake & NSF options cannot be used with thread guards (Specify **TG1** for metal).

## Mounting Options

**Standard Mounting (no code necessary):**  
3/8" diameter - 16UNC x 1 1/4" long threaded 1 1/8".

**MTG51:** 3/8" diameter - 24NF x 1 1/16" long  
To order optional mounting, add mounting code to Stem Caster Models number (Example: 1.01654.441 MTG51).

# 1 Series

Capacity up to **145 lbs each**

THREADED STEM



### Standard Dimensions

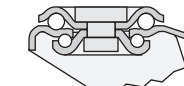
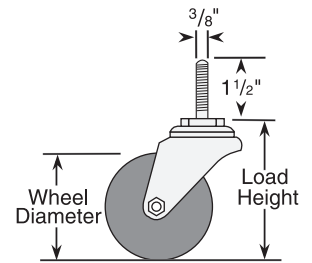

Swivel Cross Section  
Fork Leg Spacing 1 5/32"

### Features

- Zinc plated finish is attractive and durable
- Full double ball hardened raceways for better performance and greater durability
- 5/16" shouldered axle with 1/4" nut
- "Colson 45" multi-temp grease lubricates in extreme hot and cold temperatures

### Standard Mounting

- Stem Size: 3/8" diameter - 16UNC x 1 1/2" long threaded 1 3/8"

**IMPORTANT:** If caster stem is to be screwed into customer equipment, the customer must add a washer to the stem that will cover the incomplete threads and support the upper race. The stem shoulder must fit tightly against the customer equipment.

### Colson 1 Series Casters • Threaded Stem • Capacity to 145 lbs each

Wheel Dia.	Tread Width	Capacity Each (Pounds)	Wheel Descriptions	Wheel Bearing	Stem Caster Models	Load Height	Swivel Radius	Weight (Pounds)
3"	7/8"	100	Polyurethane HI-TECH	Delrin	1.03354.91	3 3/4"	2 13/16"	1 1/8
		125	Performa Rubber	Delrin	1.03354.441	3 3/4"	2 13/16"	1 1/8
			Polyolefin	Delrin	1.03354.53	3 3/4"	2 13/16"	1 1/8
4"	7/8"	125	Polyurethane HI-TECH	Delrin	1.04354.91	4 3/4"	3 7/16"	1 3/8
		135	Performa Rubber	Delrin	1.04354.441	4 3/4"	3 7/16"	1 3/8
			Polyolefin	Delrin	1.04354.53	4 3/4"	3 7/16"	1 3/8
5"	7/8"	140	Polyurethane HI-TECH	Delrin	1.05354.91	5 3/4"	4 1/16"	1 5/8
		145	Performa Rubber	Delrin	1.05354.441	5 3/4"	4 1/16"	1 5/8
			Polyolefin	Delrin	1.05354.53	5 3/4"	4 1/16"	1 5/8

### Caster Brake



**Side Lock** (See page 96)  
Available on all models. Field installable (Specify BRK3).

### Fork Options

**NSF Listed for Food Service Industry**  
All models except thread guards.

#### Forks Only

To order caster forks only use 1st 6 digits of model numbers (Example: 1.03354).

### Wheel Selection

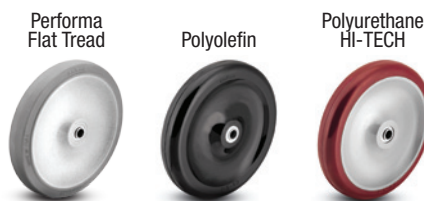

### Wheel Option

#### Thread Guards

(See page 108) Available on all 3" models.  
Brake & NSF options cannot be used with thread guards (Specify TG1 for metal).

1 Series

Colson

# 1 Series

SQUARE STEM

Capacity up to **145 lbs each**



### Standard Dimensions

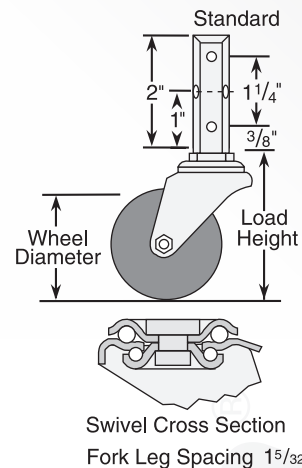

### Features

- Zinc plated finish is attractive and durable
- Full double ball hardened raceways for better performance and greater durability
- 5/16" shouldered axle with 1/4" nut
- "Colson 45" multi-temp grease lubricates in extreme hot and cold temperatures

### Standard Mounting

- Designed for easy installation on the inside of angle iron legs or against flat surfaces
- Stems may be bolted or riveted against any flat vertical surface
- Stem Size: 2" long x 3/4" square with 3 mounting holes 17/64" diameter

### Colson 1 Series Casters • Square Stem • Capacity to 145 lbs each

Wheel Dia.	Tread Width	Capacity Each (Pounds)	Wheel Descriptions	Wheel Bearing	Stem Caster Models	Load Height	Swivel Radius	Weight (Pounds)
3"	7/8"	100	Polyurethane HI-TECH	Delrin	1.03370.91	3 3/4"	2 13/16"	1 1/4
		125	Performa Rubber	Delrin	1.03370.441	3 3/4"	2 13/16"	1 1/4
			Polyolefin	Delrin	1.03370.53	3 3/4"	2 13/16"	1 1/4
4"	7/8"	125	Polyurethane HI-TECH	Delrin	1.04370.91	4 3/4"	3 7/16"	1 1/2
		135	Performa Rubber	Delrin	1.04370.441	4 3/4"	3 7/16"	1 1/2
			Polyolefin	Delrin	1.04370.53	4 3/4"	3 7/16"	1 1/2
5"	7/8"	140	Polyurethane HI-TECH	Delrin	1.05370.91	5 3/4"	4 1/16"	1 3/4
		145	Performa Rubber	Delrin	1.05370.441	5 3/4"	4 1/16"	1 3/4
			Polyolefin	Delrin	1.05370.53	5 3/4"	4 1/16"	1 3/4

### Caster Brake



**Side Lock**  
(See page 96) Available on all models. Field installable (Specify **BRK3**).

### Fork Options

**NSF Listed for Food Service Industry**  
All models except thread guards.

#### Forks Only

To order caster forks only use 1st 6 digits of model numbers (Example: 1.03370).

### Wheel Selection

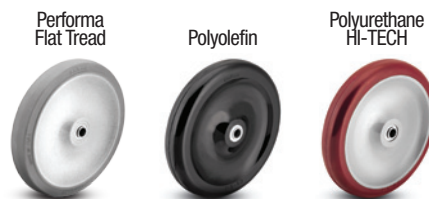

### Wheel Option

#### Thread Guards

(See page 108) Available on all 3" models. Brake & NSF options cannot be used with thread guards (Specify **TG1** for metal).

### Mounting Options

**Standard Mounting (no code necessary):**  
2" long x 3/4" square with 3 mounting holes 17/64" diameter.

**MTG1:** Optional Square Stem:  
2" long x 7/8" square with 1 mounting hole 17/64" diameter.

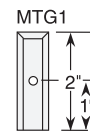

To order optional mounting, add mounting code above to Stem Caster Models number (Example: 1.03370.91 MTG1).

# 1 Series

Capacity up to 75 lbs each

SMALL TOP PLATE Swivel & Rigid



### Features

- Zinc plated finish is attractive and durable
- Full double ball hardened raceways for better performance and greater durability
- 5/16" shouldered axle with 1/4" nut
- "Colson 45" multi-temp grease lubricates in extreme hot and cold temperatures

### Standard Mounting

- Rigid caster mounting holes do not match swivel



### Standard Dimensions

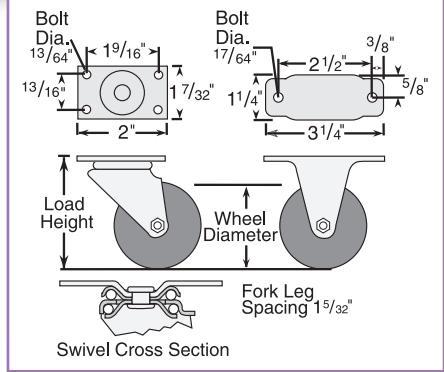

### Colson 1 Series Casters • Small Top Plate Swivel and Rigid • Capacity to 75 lbs each

Wheel Dia.	Tread Width	Capacity Each (Pounds)	Wheel Descriptions	Wheel Bearing	Swivel Top Plate Caster Models	Rigid Top Plate Caster Models	Load Height	Swivel Radius	Weight (Pounds)
1 5/8"	7/8"	60	Performa Rubber	Delrin	1.01666.441	1.01610.441	29/16"	1 3/4"	3/8
		75	Polyolefin	Delrin	1.01666.52	1.01610.52	29/16"	1 3/4"	3/8
2"	7/8"	75	Performa Rubber	Delrin	1.02266.441	1.02210.441	2 3/4"	1 15/16"	1/2
			Polyolefin	Delrin	1.02266.52	1.02210.52	2 3/4"	1 15/16"	1/2
			Cushion Rubber	Ball	1.02266.45	1.02210.45	2 3/4"	1 15/16"	1/2
			Hard Rubber	Ball	1.02266.55	1.02210.55	2 3/4"	1 15/16"	1/2
3"	7/8"	75	Performa Rubber	Delrin	1.03066.441	—	3 7/8"	29/16"	3/4
			Polyurethane HI-TECH	Delrin	1.03066.91	—	3 7/8"	29/16"	3/4
			Polyolefin	Delrin	1.03066.53	—	3 7/8"	29/16"	3/4

### Caster Brake



**Side Lock** (See page 96)  
Available on all 3" swivel models. Field installable (Specify BRK3).

### Wheel Selection

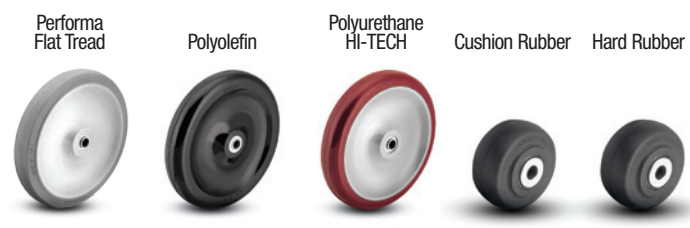

### Fork Options

**NSF Listed for Food Service Industry**  
All models except thread guards.

**Forks Only**  
To order caster forks only use 1st 6 digits of model numbers (Example: 1.01666).

### Wheel Option

**Thread Guards**  
(See page 108) Available on all 3" models. Brake & NSF options cannot be used with thread guards (Specify TG1 for metal).

Colson 1 Series





# 1 Series

TOP PLATE Swivel & Rigid  
Capacity up to 75 lbs each

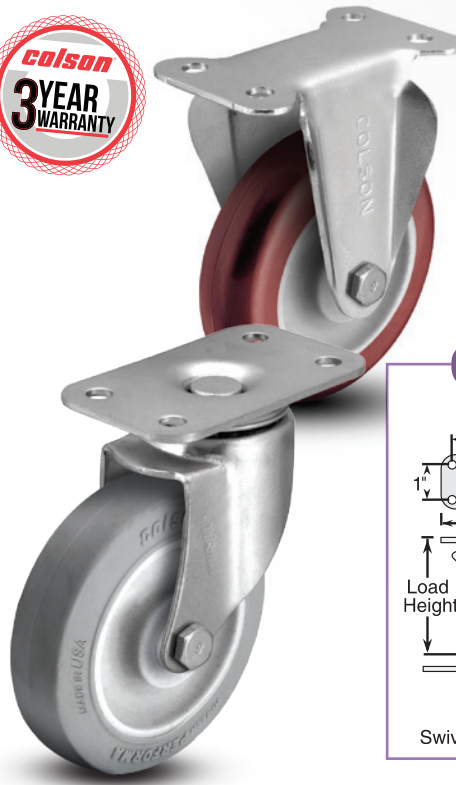

### Standard Dimensions

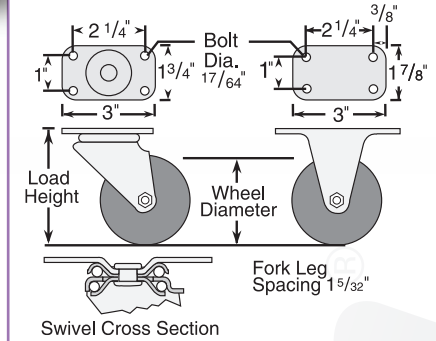

### Features

- Zinc plated finish is attractive and durable
- Full double ball hardened raceways for better performance and greater durability
- 5/16" shouldered axle with 1/4" nut
- "Colson 45" multi-temp grease lubricates in extreme hot and cold temperatures

### Standard Mounting

- Rigid caster available with 3" diameter wheel only

### Colson 1 Series Casters • Top Plate Swivel and Rigid • Capacity to 75 lbs each

Wheel Dia.	Tread Width	Capacity Each (Pounds)	Wheel Descriptions	Wheel Bearing	Swivel Top Plate Caster Models	Rigid Top Plate Caster Models	Load Height	Swivel Radius	Weight (Pounds)
1 5/8"	7/8"	60	Perfoma Rubber	Delrin	1.01656.441	—	2 9/16"	1 3/4"	1/2
		75	Polyolefin	Delrin	1.01656.52	—	2 9/16"	1 3/4"	1/2
2"	7/8"	75	Perfoma Rubber	Delrin	1.02256.441	—	2 3/4"	1 15/16"	1/2
			Polyolefin	Delrin	1.02256.52	—	2 3/4"	1 15/16"	1/2
			Cushion Rubber	Ball	1.02256.45	—	2 3/4"	1 15/16"	5/8
			Hard Rubber	Ball	1.02256.55	—	2 3/4"	1 15/16"	5/8
3"	7/8"	75	Perfoma Rubber	Delrin	1.03056.441	1.03010.441	3 7/8"	2 9/16"	3/4
			Polyurethane HI-TECH	Delrin	1.03056.91	1.03010.91	3 7/8"	2 9/16"	3/4
			Polyolefin	Delrin	1.03056.53	1.03010.53	3 7/8"	2 9/16"	3/4

### Caster Brake



**Side Lock**  
(See page 96) Available on all 3" swivel models. Field installable (Specify BRK3).

### Fork Option

**NSF Listed for Food Service Industry**  
All models except thread guards.

**Forks Only**  
To order caster forks only use 1st 6 digits of model numbers (Example: 1.01656).

### Wheel Selection



### Wheel Option

**Thread Guards**  
(See page 108) Available on all 3" models. Brake & NSF options cannot be used with thread guards (Specify TG1 for metal).

# 1 Series

Capacity up to **145 lbs each**

**LARGE TOP PLATE** Swivel & Rigid



### Standard Dimensions

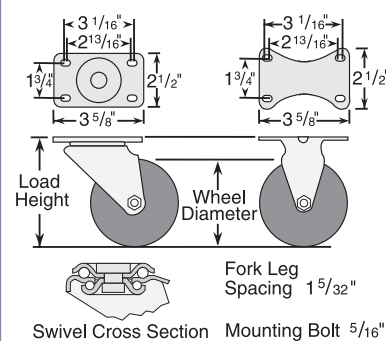

### Features

- Zinc plated finish is attractive and durable
- Full double ball hardened raceways for better performance and greater durability
- 5/16" shouldered axle with 1/4" nut
- .090" steel top plate
- "Colson 45" multi-temp grease lubricates in extreme hot and cold temperatures

### Colson 1 Series Casters • Large Top Plate Swivel and Rigid • Capacity to 145 lbs each

Wheel Dia.	Tread Width	Capacity Each (Pounds)	Wheel Descriptions	Wheel Bearing	Swivel Top Plate Caster Models	Rigid Top Plate Caster Models	Load Height	Swivel Radius	Weight (Pounds)
3"	7/8"	100	Polyurethane HI-TECH	Delrin	1.03356.91	1.03008.91	3 3/4"	2 13/16"	1 1/4
		125	Performa Rubber	Delrin	1.03356.441	1.03008.441	3 3/4"	2 13/16"	1 1/4
			Polyolefin	Delrin	1.03356.53	1.03008.53	3 3/4"	2 13/16"	1 1/4
4"	7/8"	125	Polyurethane HI-TECH	Delrin	1.04356.91	1.04008.91	4 3/4"	3 7/16"	1 1/2
		135	Performa Rubber	Delrin	1.04356.441	1.04008.441	4 3/4"	3 7/16"	1 1/2
			Polyolefin	Delrin	1.04356.53	1.04008.53	4 3/4"	3 7/16"	1 1/2
5"	7/8"	140	Polyurethane HI-TECH	Delrin	1.05356.91	1.05008.91	5 3/4"	4 1/16"	1 3/4
		145	Performa Rubber	Delrin	1.05356.441	1.05008.441	5 3/4"	4 1/16"	1 3/4
			Polyolefin	Delrin	1.05356.53	1.05008.53	5 3/4"	4 1/16"	1 3/4

### Caster Brake



**Side Lock**  
(See page 96) Available on all swivel models. Field installable (Specify **BRK3**).

### Fork Option

**NSF Listed for Food Service Industry**  
All models except thread guards.

### Forks Only

To order caster forks only use 1st 6 digits of model numbers (Example: 1.03356).

### Wheel Selection

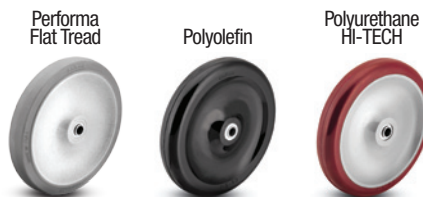

### Wheel Option

**Thread Guards**  
(See page 108) Available on all 3" models. Brake & NSF options cannot be used with thread guards (Specify **TG1** for metal).

1 Series

Colson