

# 1000 SERIES

# 150LBS

casterdepot.com



## FEATURES

**KINGPIN:** 7/16" rivet  
**RACEWAY:** 7/32" diameter upper race; 7/32" diameter lower race; hardened steel load bearings  
**BUSHING:** Nylon, steel or ball bearing  
**AXLE&NUT:** 5/16" axle and lock nut  
**FINISH:** Corrosion resistant bright zinc

**HARDENED:** Yoke and washers  
**SPECIAL:** Most stems available for swivel and rigid casters. Rigid TLB available. Upper and lower race diameter is equal for added performance and strength  
**LEG SPACING:** 1 1/4" (standard), 1 7/16" (for 1 1/4" tread wheels)

### EXCELLENT FOR:

- Institutional furniture
- Hospitals
- Food service equipment
- Tool boxes
- Store fixtures
- Audio & Visual Aid equipment



### OPTIONS:

- TLB** Top Locking Brake (swivel and rigid) (for 1" tread wheels only)
- SLB** Side Locking Brake (swivel and rigid)  
 \*SLB will not work with BB or TG
- AR** Riveted Axle
- BB** Sealed Ball Bearings (U and UG wheels only)  
 \*BB will not work with 1 1/4" tread wheels
- CD** Cross Drilled holes
- TG** Thread Guards
- Z** Zerk Axle and Lock Nut

### FINISHES:

- 10?2 Chrome  
 10?4 Black  
 10?5 Yellow Chromate  
 Inquiries on other finishes welcome

WHEEL		CASTER				PART NUMBER									
Diameter	Tread Width	Capacity Lbs.	Bearing Type	Swivel Radius	Overall Height	Wheel Type	Swivel	Caster Weight (lbs)	Rigid	Caster Weight (lbs)					
3"	1"	150	Nylon	2 9/16"	3 13/16"	Soft Rubber	S1033-***-SR	1.10	R1033-***-SR	0.86					
		150	Nylon			Envirothane™	S1033-***-U	1.06	R1033-***-U	0.82					
		150	Nylon			Envirothane™ Grey	S1033-***-UG	1.06	R1033-***-UG	0.82					
	1 1/4"	150	Steel	2 9/16"	3 13/16"	Hard Rubber	S1033-***-1 1/4HR	1.31	R1033-***-1 1/4HR	1.06					
			Steel			Hard Rubber Grey	S1033-***-1 1/4HRG	1.35	R1033-***-1 1/4HRG	1.10					
			Steel			High Temp Phenolic (475°)	S1033-***-1 1/4HTPH	1.29	R1033-***-1 1/4HTPH	1.04					
			Steel			Phenolic	S1033-***-1 1/4PH	1.18	R1033-***-1 1/4PH	0.93					
			Plain			Polyolefin	S1033-***-1 1/4PO	0.95	R1033-***-1 1/4PO	0.70					
			Nylon			ProTech™ Flat	S1033-***-1 1/4PROF	1.03	R1033-***-1 1/4PROF	0.78					
			Nylon			ProTech™ Flat Blue	S1033-***-1 1/4PROFB	1.03	R1033-***-1 1/4PROFB	0.78					
			Steel			Soft Rubber	S1033-***-1 1/4SR	1.23	R1033-***-1 1/4SR	0.98					
			Steel			Soft Rubber Grey	S1033-***-1 1/4SRG	1.23	R1033-***-1 1/4SRG	0.98					
Nylon	Envirothane™	S1033-***-1 1/4U	1.12	R1033-***-1 1/4U	0.87										
Nylon	Envirothane™ Grey	S1033-***-1 1/4UG	1.12	R1033-***-1 1/4UG	0.87										
4"	1"	150	Plain	3 3/16"	4 13/16"	Polyolefin	S1043-***-PO	1.06	R1043-***-PO	0.83					
		150	Nylon			Soft Rubber	S1043-***-SR	1.55	R1043-***-SR	1.32					
		150	Steel			Soft Rubber Grey	S1043-***-SRG	1.61	R1043-***-SRG	1.39					
		150	Nylon			Envirothane™	S1043-***-U	1.30	R1043-***-U	1.08					
	1 1/4"	150	Nylon	Envirothane™ Grey	S1043-***-UG	1.30	R1043-***-UG	1.08							
			Steel	3 3/16"	4 13/16"	Hard Rubber	S1043-***-1 1/4HR	1.72	R1043-***-1 1/4HR	1.50					
			Steel			Hard Rubber Grey	S1043-***-1 1/4HRG	1.79	R1043-***-1 1/4HRG	1.57					
			Steel			High Temp Phenolic (475°)	S1043-***-1 1/4HTPH	1.80	R1043-***-1 1/4HTPH	1.58					
			Steel			Phenolic	S1043-***-1 1/4PH	1.59	R1043-***-1 1/4PH	1.37					
			Nylon			ProTech™ Flat	S1043-***-1 1/4PROF	1.26	R1043-***-1 1/4PROF	1.03					
			Nylon			ProTech™ Flat Blue	S1043-***-1 1/4PROFB	1.26	R1043-***-1 1/4PROFB	1.04					
			Steel			Soft Rubber	S1043-***-1 1/4SR	1.60	R1043-***-1 1/4SR	1.38					
			Steel			Soft Rubber Grey	S1043-***-1 1/4SRG	1.60	R1043-***-1 1/4SRG	1.38					
			Nylon			Envirothane™	S1043-***-1 1/4U	1.39	R1043-***-1 1/4U	1.17					
			Nylon			Envirothane™ Grey	S1043-***-1 1/4UG	1.39	R1043-***-1 1/4UG	1.17					
			5"			1"	150	Plain	3 3/4"	5 13/16"	Polyolefin	S1053-***-PO	1.12	R1053-***-PO	0.90
							150	Nylon			Soft Rubber	S1053-***-SR	1.73	R1053-***-SR	1.51
							150	Steel			Soft Rubber Grey	S1053-***-SRG	1.76	R1053-***-SRG	1.55
150	Nylon	Envirothane™					S1053-***-U	1.54			R1053-***-U	1.32			
150	Nylon	Envirothane™ Grey		S1053-***-UG	1.54		R1053-***-UG	1.32							
1 1/4"	150	Steel		3 3/4"	5 13/16"	Hard Rubber	S1053-***-1 1/4HR	2.21	R1053-***-1 1/4HR	2.00					
		Steel				High Temp Phenolic (475°)	S1053-***-1 1/4HTPH	2.38	R1053-***-1 1/4HTPH	2.17					
		Steel				Phenolic	S1053-***-1 1/4PH	2.03	R1053-***-1 1/4PH	1.82					
		Plain				Polyolefin	S1053-***-1 1/4PO	1.28	R1053-***-1 1/4PO	1.07					
		Steel				Soft Rubber	S1053-***-1 1/4SR	2.13	R1053-***-1 1/4SR	1.92					
		Steel				Soft Rubber Grey	S1053-***-1 1/4SRG	2.13	R1053-***-1 1/4SRG	1.92					
		Nylon				Envirothane™	S1053-***-1 1/4U	1.66	R1053-***-1 1/4U	1.45					
Nylon	Envirothane™ Grey	S1053-***-1 1/4UG	1.66	R1053-***-1 1/4UG	1.45										

\* Caster weight based on Standard Plate

## PLATE DIAGRAMS

STANDARD PLATE: **A28D**

Plate Thickness: 3/32"



Threaded Stem HW



Threaded Stem HN

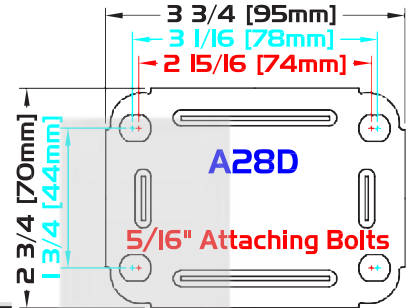

### THREADED STEMS HEX WASHER

***	DIAMETER	LENGTH	TYPE
3/8-16X1HW *	3/8"	1"	NC
1/2-13X1HW	1/2"	1"	NC
1/2-13X1 1/2HW	1/2"	1 1/2"	NC
1/2-13X2 1/4HW	1/2"	2 1/4"	NC

\* Weight capacity of caster is 125lbs

### THREADED STEMS HEX NUT

***	DIAMETER	LENGTH	TYPE
1/2-13X1HN	1/2"	1"	NC
1/2-13X1 7/8HN	1/2"	1 7/8"	NC
1/2-13X3 1/2HN	1/2"	3 1/2"	NC

### ROUND STEMS

***	DIAMETER	LENGTH	TYPE
437X1 7/8	7/16"	1 7/8"	Plain
437SX1	7/16"	1"	Friction Ring
437SX1 5/16	7/16"	1 5/16"	Friction Ring
437SX1 7/8	7/16"	1 7/8"	Friction Ring
625S	5/8"	1 5/8"	Friction Ring
812S	13/16"	2"	Friction Ring
862S	.862"	2"	Friction Ring
875S	7/8"	2"	Friction Ring
995S	.995"	2 1/2"	Friction Ring
1.050S	1 3/64"	2 1/2"	Friction Ring

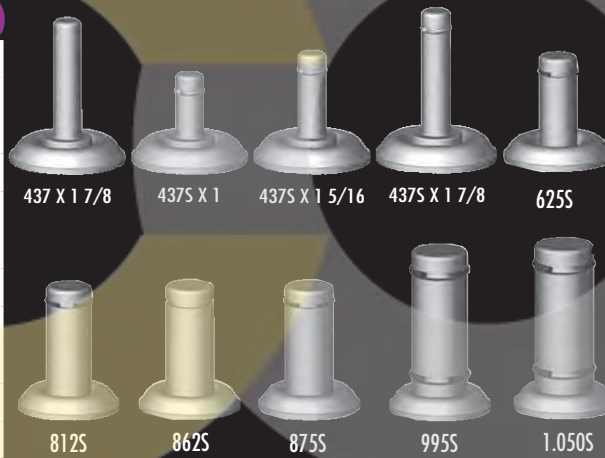

\* Tapped holes upon request.  
 \*\* Special CD hole locations upon request.  
 \*\*\* Friction rings not applied with cross drill

### SQUARE STEMS

***	DIAMETER	LENGTH
3/4SQ	3/4"	2"
7/8SQ	7/8"	2"

\* Tapped holes upon request.  
 \*\* Special CD hole locations upon request.  
 \*\*\* Friction rings not applied with cross drill

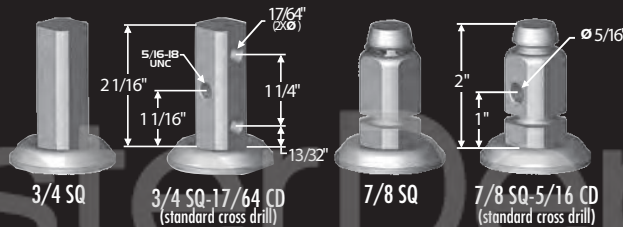

### SPECIAL STEMS

***	DIAMETER	LENGTH
3/4NPT	1"	3/4"
EXP	1 1/2"	3 1/2"

